

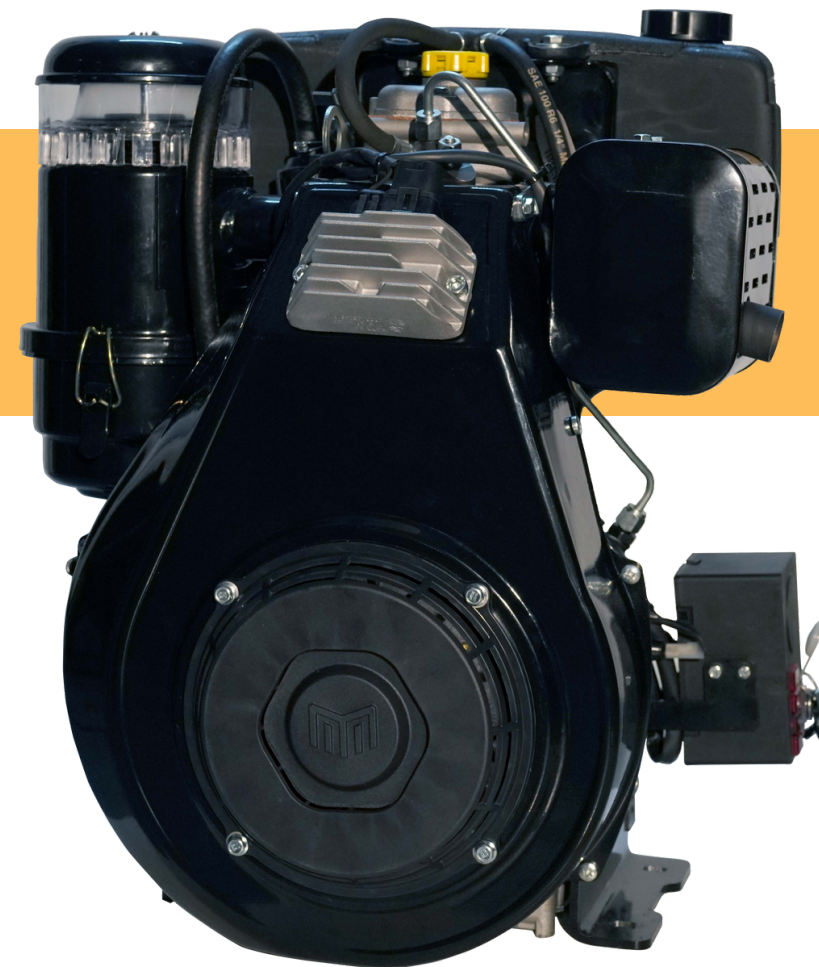

TMRF Serie Diesel



Modello		TMRF120	TMRF120/ S	
Numero di Cilindri		1	1	
Diametro/ Alessaggio	mm	90 x 85	90 x 85	
Dislocamento	cm ³	541	541	
Rapporto di Compressione		18:1	18:1	
Potenza	(NDIN70020)	Kw (HP)	9 (12.2)	9.5 (13)
	NB(DIN6270)	Kw (HP)	8.2 (11.2)	8.8 (12)
	(NDIN70020)	Kw (HP)	7.6 (10.3)	8.2 (11.2)
Velocità	rpm	3000	3600	
Coppia Massima	(RN@rpm)	31@2400	31@2400	
Capacità Serbatoio	L	5.5	5.5	
Capacità Coppia Olio	L	2	2	
Peso a Secco	kg	56	56	

	AVVIAMENTO ELETTRICO	AVVIAMENTO A STRAPPO
ROTAZIONE SINISTRA	TMRF120AESX	TMRF120ASSX
ROTAZIONE DESTRA	TMRF120AEDX	TMRF120ASDX

FILTRO ARIA
L'aspirazione migliore
tipo 3LD Lombardini



MARMITTA Silenziata con
il meglio della qualità
Lombardini 16/18 Hp



SERBATOIO in plastica
dando più vita al motore e
creando meno ruggine
FILTRO NAFTA ad immersione
tipo Yanmar

SHORT BLOCK
Cuore del motore tipo
Serie Ruggerini RF



RICHIEDI IL TIPO DI ALBERO CHE PREFERISCI

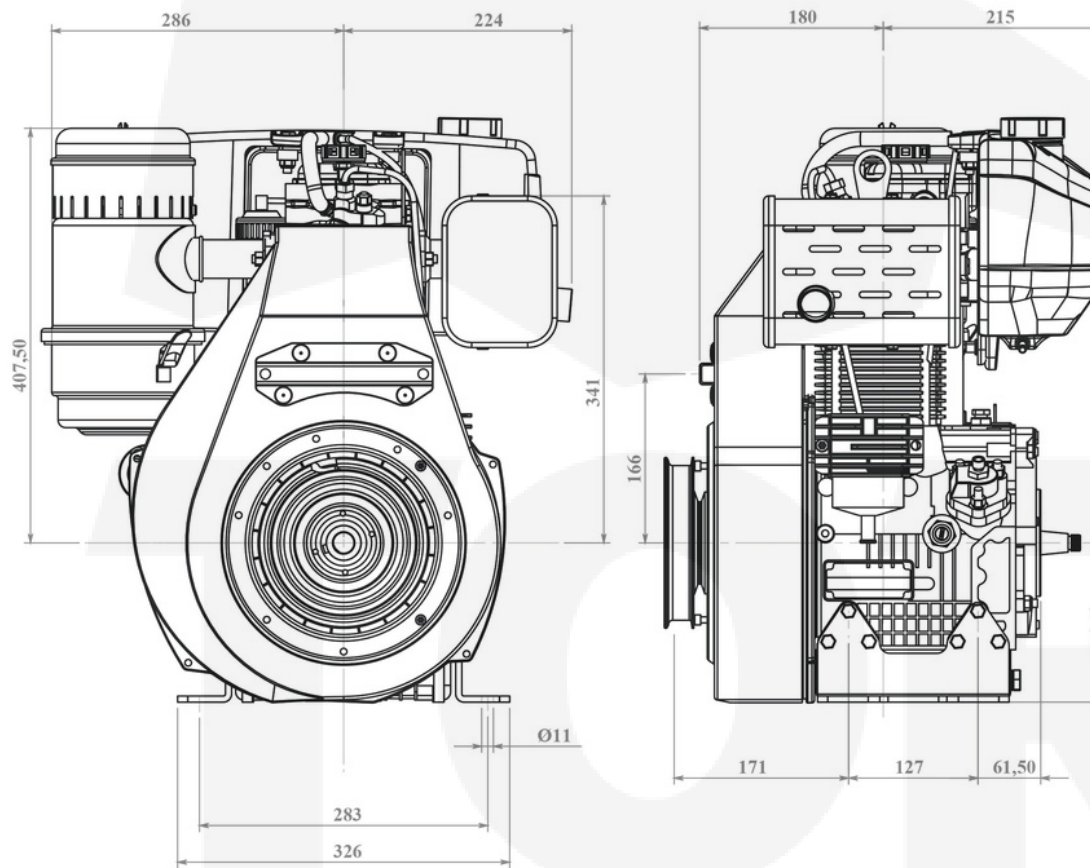

Filettatura esterna

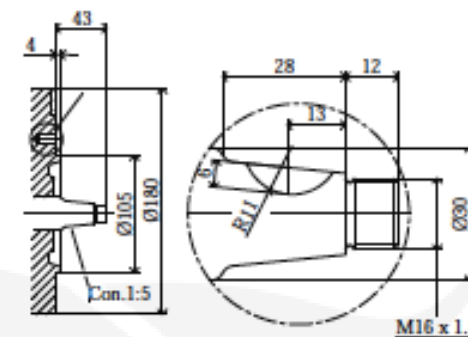

Filettatura interna

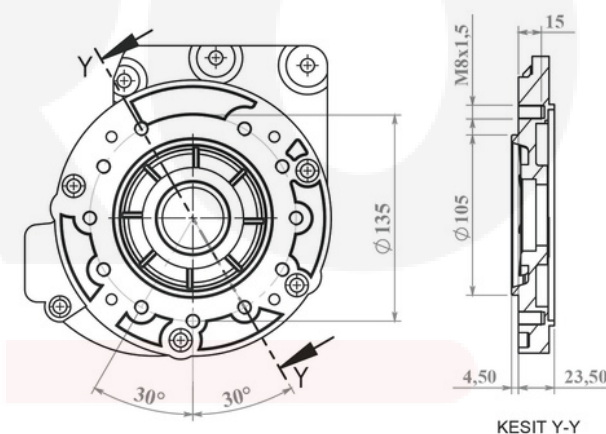
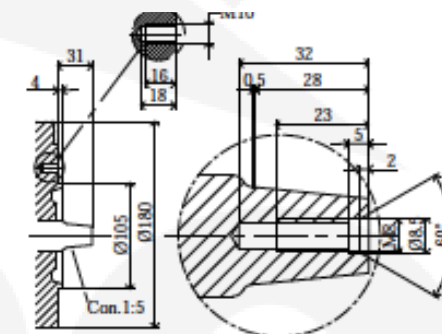



TMRF 120 - TMRF 120/S

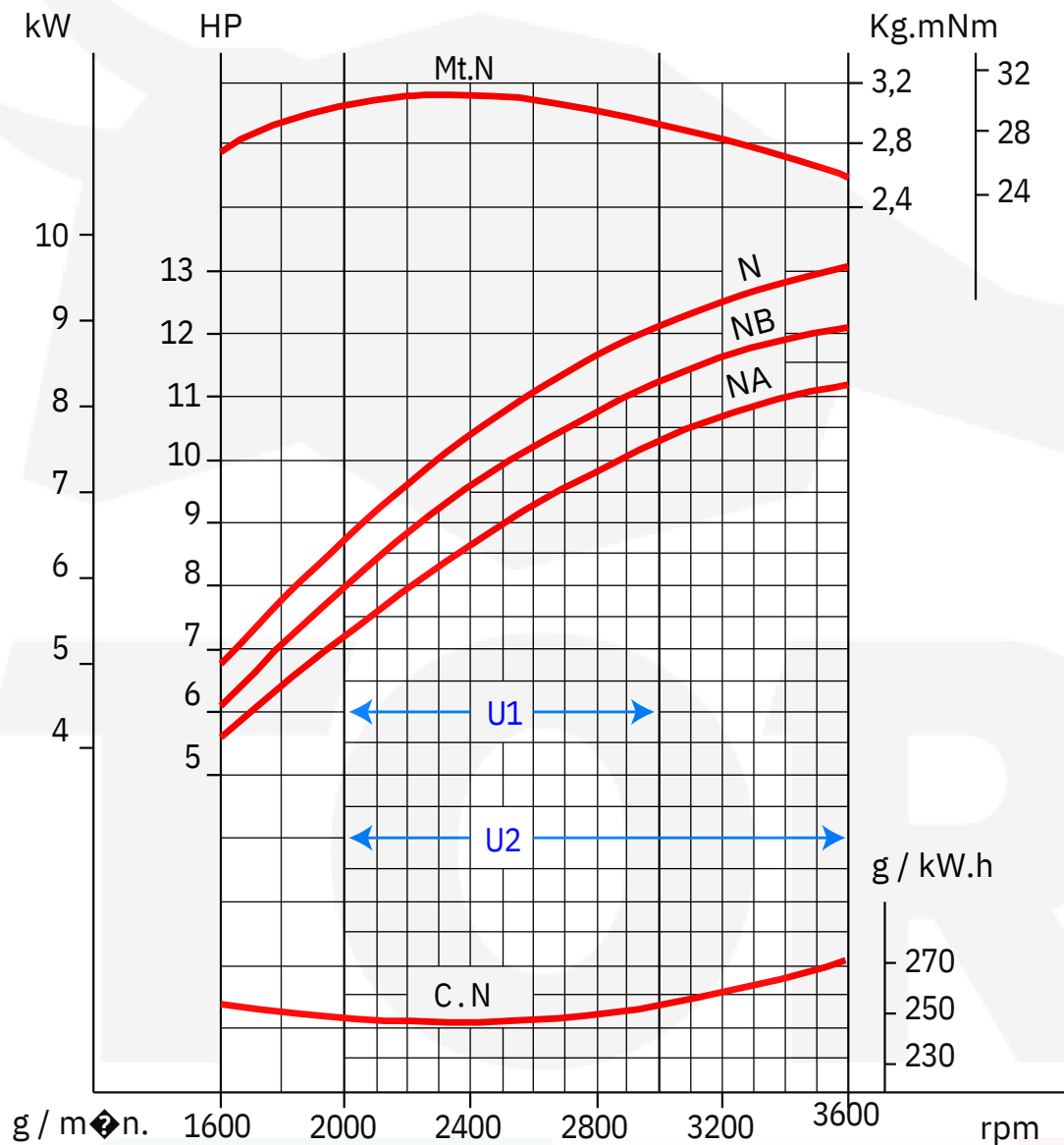

U1: UTILIZZO STANDARD DEL TMRF 120

U2: UTILIZZO STANDARD DEL TMRF 120/S